



**The Fletcher-Terry Company, LLC**

# OWNER'S MANUAL

---

## Fletcher F-60 Cutter

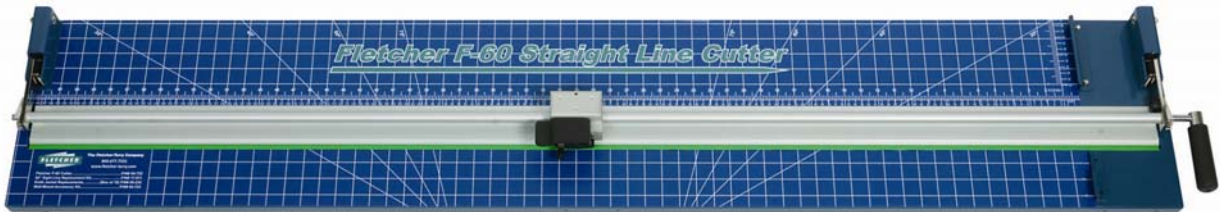

### **The Fletcher-Terry Company**

91 Clark Drive • East Berlin, CT USA 06023

Tel 860.677.7331 • Toll-Free (U.S. only) 888.888.5165 • Fax 860.828.3400  
[customerservice@fletcher-terry.com](mailto:customerservice@fletcher-terry.com) • [www.fletcher-terry.com](http://www.fletcher-terry.com)

**Form ENG - 052212**

# TABLE OF CONTENTS

INTRODUCTION.....	i
PRODUCT WARRANTY.....	i
SAFTEY FIRST.....	ii
<b>I.     <u>OPERATION OF THE F-60 CUTTER</u></b>	
a. Unpacking materials.....	1.
b. Operating Rail Clamp Mechanism.....	2.
c. Plastic Knife Blade Cartridge.....	2.
d. Inserting Plastic Knife Blade.....	3.
<b>II.    Trimming Green Sight-Line Strip to Size.....</b>	<b>3.</b>
<b>III.   F-60 Cutting Head – Operating Lock and Cut Feature.....</b>	<b>4.</b>
<b>IV.    General Maintenance Tips.....</b>	<b>4.</b>
<b>V.     F-60 Cutting Head – Field Adjustment.....</b>	<b>4.</b>
<b>VI.    Troubling Shooting Guide.....</b>	<b>5.</b>
<b>VII.   Common Consumables and Accessories.....</b>	<b>5.</b>
<b>VIII.  Parts List – Main Table Assembly.....</b>	<b>5.</b>
<b>IX.    Parts List – Cutting Head Assembly.....</b>	<b>7.</b>

# INTRODUCTION

Congratulations on purchasing a Fletcher F-60 Cutter. You have a tool that will perform consistently and made of a long-lasting durable material. The F-60 is perfect for all your cutting needs—cutting corrugated plastic, Gatorboard, foamboard up to ½” (13mm) and PVC up to 3mm.

Please read the operating instructions and the **SAFETY FIRST!** section carefully BEFORE you operate your Fletcher Cutter to make sure you get the best performance from your purchase. If you have any questions, you can find more information at Fletcher’s website at [www.fletcher-terry.com](http://www.fletcher-terry.com) or contact our Customer Service Department toll-free at 800.843.3826 in the United States. Outside the United States, call ++860.828.3400.

## **Product Warranty**

The Fletcher-Terry Company warrants the machine purchased to be free from defects in parts and workmanship for five (5) years from the date of purchase. The Fletcher-Terry Company warrants that it will repair or replace any such defective machine or replace parts, providing the machine has been under normal use and service and the defective part or machine is returned to The Fletcher-Terry Company at the purchaser’s expense. The Fletcher-Terry Company must authorize the return in writing. Proof of purchase must be submitted to validate warranty coverage. The warranty is in lieu of all other agreements and warranties expressed or implied. THE FLETCHER-TERRY COMPANY DOES HEREBY EXPRESSLY DISCLAIM ANY WARRANTIES OF MERCHANT ABILITY OR FITNESS FOR A PARTICULAR PURPOSE. The Fletcher-Terry Company does not authorize any company employee or representative to assume for it any other liability than that set forth in this Product Warranty. The Fletcher-Terry Company shall not be liable for any damages or losses, whether incidental or consequential, or direct or indirect, arising out of the use or abuse of this machine. This Warranty is valid only when machine is used with Fletcher consumables and replacement parts. In any event, THE PURCHASER’S SOLE AND EXCLUSIVE REMEDY UNDER THIS OR ANY OTHER WARRANTY IS LIMITED TO RETURN OF THE PURCHASE PRICE PAID FOR THIS MACHINE.

# **SAFETY FIRST!**

Please read through this manual before operating the Fletcher F-60. If after reviewing these pages you still have questions about using the machine, contact our Customer Service Department toll-free at 800.843.3826 in the United States. Outside the United States, call +860.828.3400 or you may email us at [customerservice@fletcher-terry.com](mailto:customerservice@fletcher-terry.com).

- It is the employer's responsibility to enforce compliance with these safety warnings and procedures by all who use the F-60. Keep this manual available so all employees have access to it and have the opportunity to review procedures periodically.
- The intended purpose of the F-60 is for cutting Gatorboard, foamboard, PVC, and corrugated plastic materials. It must not be modified or used for any other application or purpose.
- Keep fingers away from the blade when cutting and cleaning the machine.
- Make sure your cutters are used on flat, level surfaces. An uneven tabletop or workbench will result in a bowed cut.
- If there is any damage to the cutting head or cutter bar assembly, **DO NOT USE THE CUTTER.**
- Remove the blade before cleaning your cutter.
- Always use safety glasses. The operator of this machine, and others in the work area, must wear safety glasses with rigid side shields.
- Only use the parts, supplies and accessories that are recommended by Fletcher-Terry.
- Make sure that the work area is well lit, free from clutter and set-up in a way that promotes proper ergonomics.

## I. OPERATION OF THE F-60

### a. Unpacking Materials

Check the exterior of the packing box to make sure there is no visible damage. After unpacking the unit, check to make sure you have all the parts and there is no damage to the machine. All components and major assemblies have already been factory installed on the F-60 Cutter.

- Rail with Cutting Head
- Three (3) Plastic Knife Blade Cartridges
- One (1) Sight-Line Guide Strip already installed

**Note:** Customer will have to trim the sight line strip to size which is covered in step II.

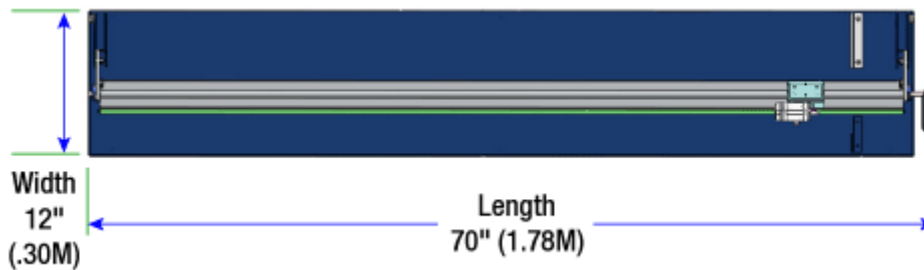
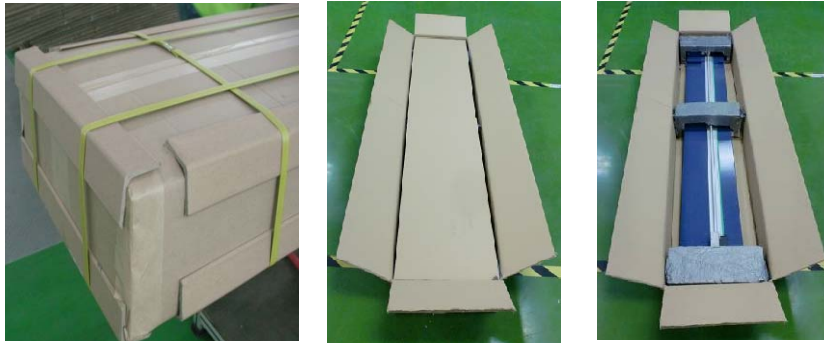

## b. Operating Rail Clamping Mechanism

The F-60 Cutter is equipped with a single lever clamping mechanism to firmly secure the material in place during the cutting process.

The clamping mechanism will securely hold material up to ½" (13mm) thick.

To raise the clamping mechanism (**UP** ↑) for placing the material to be cut, grip the black handle lever and raise up to almost a 90° angle for clamp to lock in place.

Place the material to be cut under and through the clamping rail, position material and again using the black handle, lower clamp (**DOWN** ↓) to secure material in place.

Utilize the built-in square bar to securely hold the material straight during the cutting process.



## c. Plastic Knife Blade Cartridge

The F-60 cutter uses a plastic knife blade cartridge for cutting a wide range of semi-rigid and flexible materials. The cutting blade is permanently molded in place and CANNOT be removed and replaced with a new blade in the plastic cartridge holder.

Once the knife blade becomes no longer effective in cutting, you will need to replace the complete knife blade jacket.

To re-order replacement blades use P/N# 05-235. Order online by going to [www.fletcher-terry.com](http://www.fletcher-terry.com), click on **Online Buying** and search under the part number.

The plastic cartridge is equipped with four different cutting depth indicators aiding the operator for setting the proper depth based on the thickness of the material to be cut. NOTE: the depth measurement is the line **BELOW** the measurement number.

Pre-determined cutting depths:

- .125 inches (3.17mm)
- .250 inches (6.35mm)
- .375 inches (9.52mm)
- .500 inches (12.7mm)



#### d. Inserting the Plastic Knife Blade Cartridge into Cutting Head

1. Remove from three (3) piece package included with the F-60 unit and hold the back end of the plastic cartridge so the blade is pointing away from the operator.
2. Loosen the “black” blade locking knob located on the lower left side of the cutting head by turning it counter-clockwise
3. Slide the plastic cartridge knife blade, blade end in first, gently against the silver plate to the .125 cutting depth. Turn the Blade Locking Knob clockwise to secure. The .125 cutting depth will be used to trim sight-line cutting strip explained in step II.



Blade Locking Knob

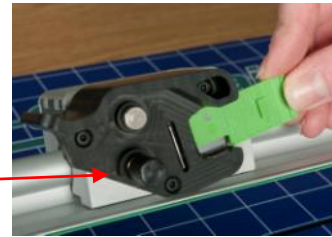

#### II. Trimming Green Sight-Line Strip to Size

The F-60 Cutter is equipped with a sight-line strip that indicates the cut line when cutting pre-printed graphics. Prior to its use, you must **FIRST** trim the strip for correct alignment to the cutting blade.

1. Make sure you set the cutting depth of the plastic knife blade cartridge to .125 inches (3.17mm)
2. First place a firm cutting board surface onto the full length of the cutting table and clamp (for example, scrap piece of foamboard)
3. Place the cutting head all the way to the left of the table – opposite end from the built-in squaring bars
4. Slightly rotate the Cutting Head forward, lightly scribe a cut line with the blade on the Sight Line Guide over the entire cut length – **do not cut all the way through**. Repeat the cut again, this time cutting completely through the Sight Line Guide. Do not lift the cutting head until the cut is complete
5. Note: There will be a portion on either end of the Green Strip that will not be cut
6. Using a utility knife, continue the cut made by the F-60 on either end and remove the excess Green Strip material.

End of Cut

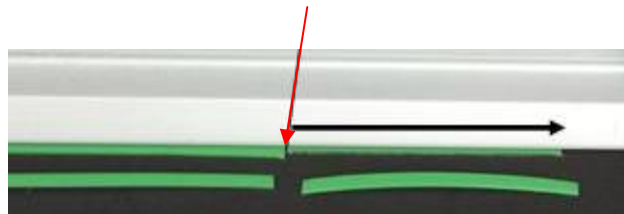

### III. F-60 Cutting Head – “Lock and Cut” Feature

The F-60 Cutter offers a unique “lock and cut” feature as part of its cutting head assembly. When the operator lowers the cutting head, it locks into the down position during the cutting process. At the end, simply **PUSH** in the **SILVER** button to reset and release the locking feature.

This feature is useful for cutting thicker, denser rigid substrates.



Showing the head lock down



Push silver button to reset

### IV. General Maintenance Tips

With care and frequent cleaning, the F-60 will remain in proper adjustment and will perform as expected indefinitely.

The most important maintenance requirement is wiping the machine frequently with a dry cloth. No oil or synthetic lubricants should be used, or the plastic components could be damaged. Silicone lubricant spray can be used on the Cutting Head Track, if necessary.



**CAUTION:** Remove the blade before cleaning the machine.

#### a. F-60 Cutting Head – Bearing Adjustment

From time to time, depending on overall usage wear, field adjustments are needed to reduce cutting head “wobbling” or right to left movement in the head caused by wear.

Tool needed: 2mm Hex Key Wrench

Adjustment Procedure: Rotate **CLOCKWISE** to tighten - **COUNTER CLOCKWISE** to loosen

Set Screw Port

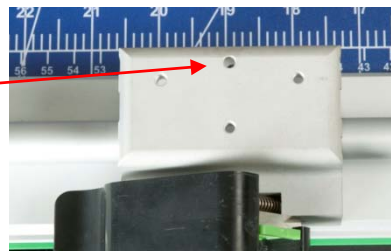



## V. Troubleshooting Guide

Check the guide below to troubleshoot some common issues during the use of your F-60 Cutter. If the Troubleshooting Guide or the Frequently Asked Questions section listed below does not answer your questions, please contact our Customer Service Department at 800.843.3826, or send an email to customerservice@fletcher-terry.com.

Symptom	Probable Cause	Correction
Ragged Edge	Blade is dull	Replace Plastic Knife Blade Cartridge
Head drags too much	Bearing is too tight	Re-adjust bearing

## VII. Common Consumables and Accessories

Part	Part Number
Plastic Knife Blade Cartridge (Box of 10)	05-235
Wall-mount Accessory Kit	04-723
Sight Line Replacement Kit	17-811

## VIII. Parts List – Main Table Assembly

Item	Part No.	Description	QTY	Item	Part No.	Description	QTY
1	17-830	Table Assembly	1	14	17-866	Pivot Arm Bushing	2
2	17-864	Clamp Extrusion	1	15	17-832	Upper/Left Pivot Arm Assembly	1
3	17-800	Yellow Grip Strip	66.5"	16	17-834	Hex Flanged Nut	2
4	17-811	Sight Line Strip	1	17	17-867	Clamp Extrusion Bushing	2
5	17-836	Cam Shaft	1	18	17-840	Cutting Head Assembly	1
6	17-837	Handle	1	19	17-881	M4x8mm HFMS	2
7	17-208	Handle Sleeve	1	20	17-882	M4 Lock Washer	2
8	17-863	Handle Spring Pin	1	21	17-835	Squaring Bar-Short	1
9	17-861	Shim Washer	2	22	17-832	Lower/Right Pivot Arm Assembly	1
10	17-857	Cam Wheel Assembly	2	23	17-883	Tension Spring	2
11	17-880	M4x12mm SHCS	2	24	17-884	M4x10mm BHCS	10
12	17-871	M10 Shoulder Screw	2	25	17-885	Bumper	10
13	17-873	Curved Spring Washer	4	26	36-063	Guide Button	2

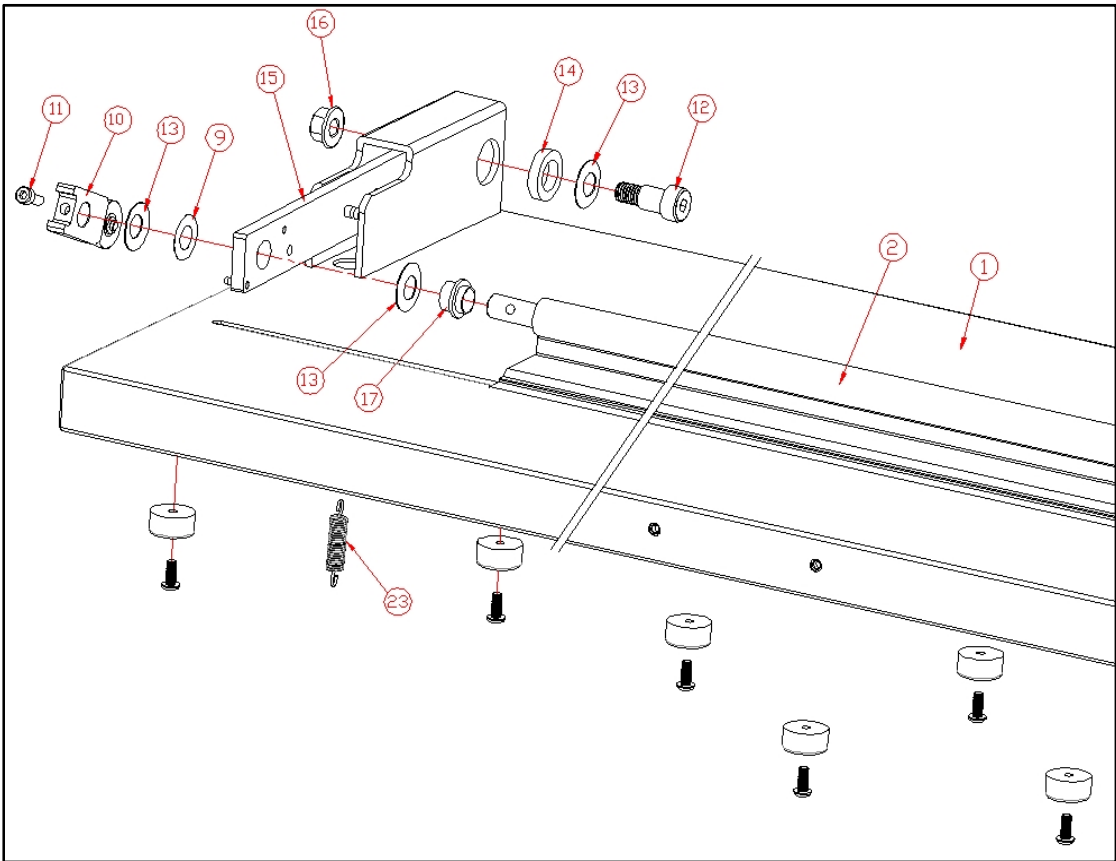

Table Exploded View – Left Side

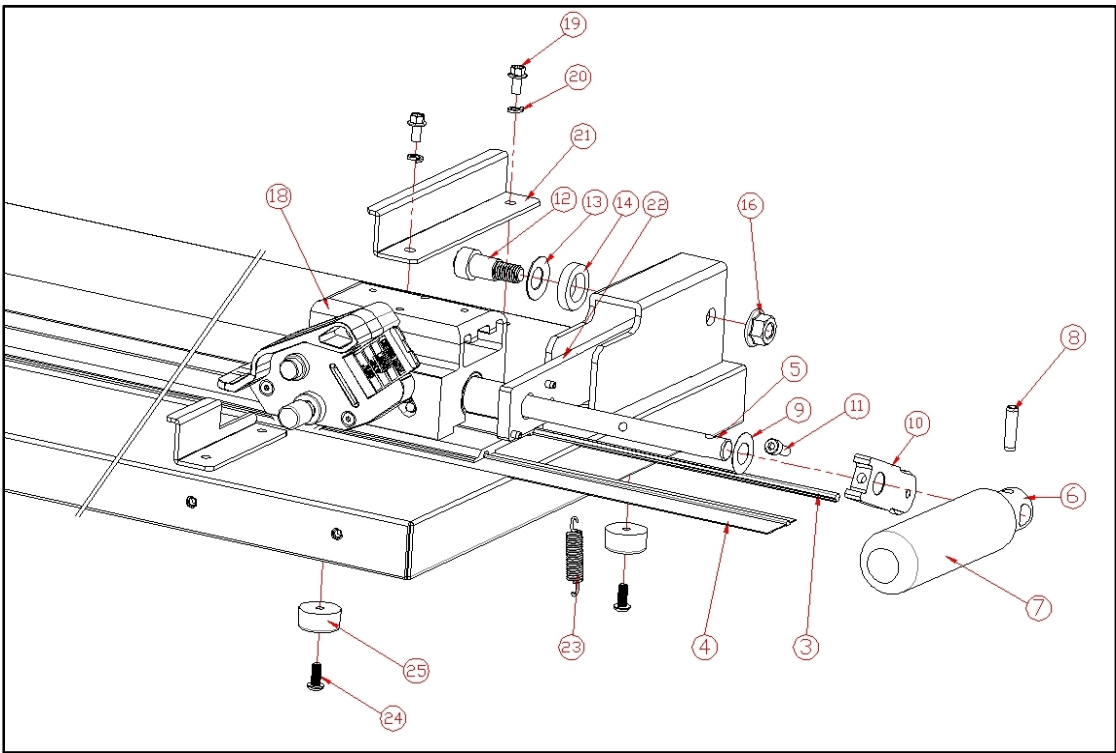

Table Exploded View – Right Side

## IX. Parts List – Cutting Head Assembly

Item	Part No.	Description	QTY	Item	Part No.	Description	QTY
1	17-841	Cutter Housing	1	11	17-849	Detent Pin	1
2	17-886	.187 Pin w/Groove	1	12	17-841	Cutter Head	1
3	17-887	.157 Pin	1	13	17-892	E-Clip	1
4	17-888	Tension Spring	1	14	17-845	Blade Clamp Plate	1
5	17-889	Trunion Pin	1	15	17-893	M3x12mm FHS	3
6	17-890	Teflon Bar	1	16	17-550	Blade Clamp Knob	1
7	17-891	Compression Spring	1	17	17-894	M4x16mm Set Screw	3
8	17-850	Detent Pin Slider	1	18	12-538	Cutter Housing Bushing	2
9	17-842	Pivot Plate Assembly	1	19	17-851	Rest Button	1
10	12-532	Pivot Screw	1				

